



# FM-11

## In-Dash Adapter Kit

### Installation Instructions

This adapter kit is designed for in-dash mounting the following products: Lowrance® LCX-37C, LCX-38C HD; GlobalMap® 8200C, GlobalMap® 8300C HD.

These instructions **MUST** be used with template part number 988-0154-691, which accompanies this instruction sheet. Please read all instructions before proceeding. **NOTE:** Recommended tools for this job include: jig saw, drill, 1-3/4" (44.45 mm) hole saw, 1/8" (3.18 mm) drill bit, Phillips head screwdriver and adjustable wrench.

1. Select the desired mounting location. Make sure there is enough room behind the dash to attach the power, network, antenna and/or transducer cables. The case with cables attached is approximately 4.50" (114.3 mm) deep behind the mounting surface. ***The maximum dash thickness that can be used with this mounting kit is 1" (25.4 mm).*** Carefully measure the dash thickness before cutting any holes.

2. Tape the template supplied with these instructions to the dash. Begin the cutout by drilling four 1-3/4" (44.45 mm) holes inside the cutout to accommodate the saw blade. Use the 1/8" (3.18 mm) drill bit to drill the four mounting screw holes where indicated on the template.

3. Slip your saw blade into one of the 1-3/4" (44.45 mm) starter holes and then saw along the indicated cutout line. Be careful when working around the corners, because there is little room for error.

4. If the installation location is exposed to weather, you may want to seal the cutout. If that's the case, before you place the unit into the opening, apply a bead of RTV silicone or other suitable sealant to the back of the unit. In addition to the outside edge, be sure to apply sealant around the four mounting screw holes, as shown in the following figure.

5. For each of the four screws provided, thread a lock nut and flat washer onto the shaft to create a total of four screw assemblies as shown in the second image.

6. Place the unit into the dash cutout. (If space is cramped, it's usually easier to connect the cables before placing the unit in the dash.)

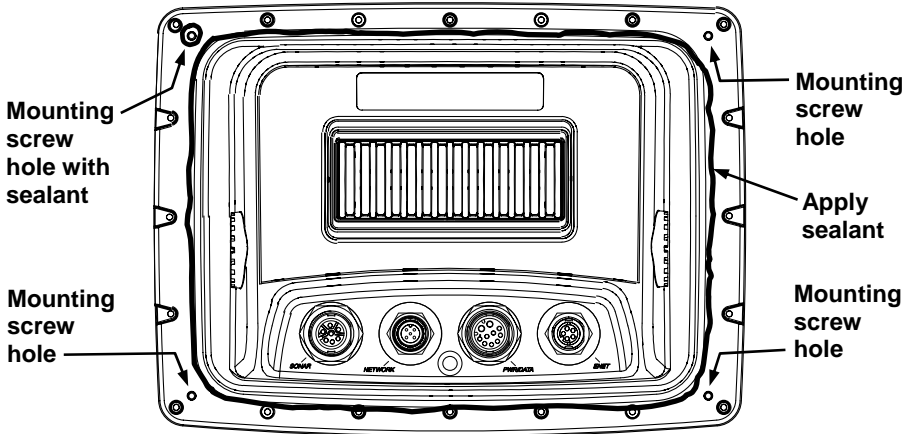

If desired, apply sealant to back of unit before installation.

7. Install the four screw assemblies in the back of the unit. Do not over tighten or else damage to the case may occur.

**WARNING:**

**Do NOT apply any thread locking compounds to mounting screws! These compounds are harmful to plastics and will damage your unit's case.**

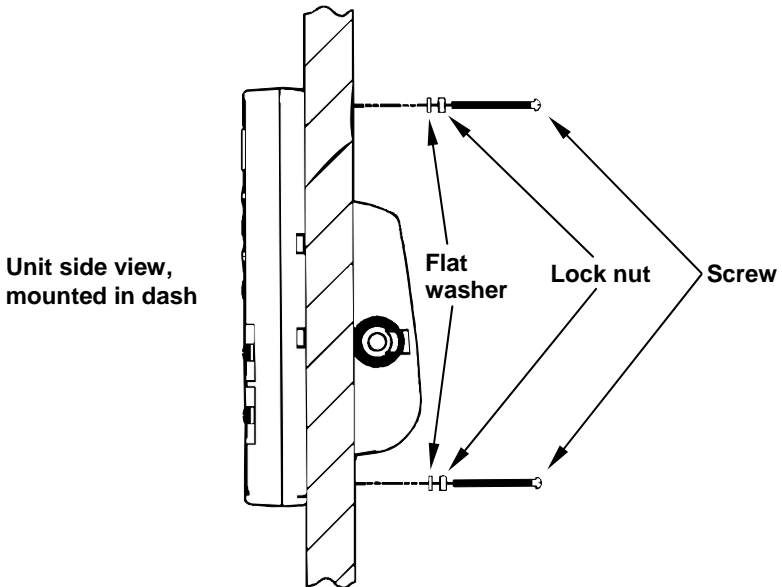

**Thread lock nut and flat washer onto screw, to create a screw assembly. Use all four screw assemblies to secure unit to dash.**

8. Next, with the screw assemblies in place, tighten the lock nuts until they are firmly seated against the dash. Do not over tighten or case damage can occur — maximum torque is 4 inch-pounds (0.452 N·m). If you haven't already done so, route the power, network, antenna and/or transducer cables to the unit and it's ready for use.

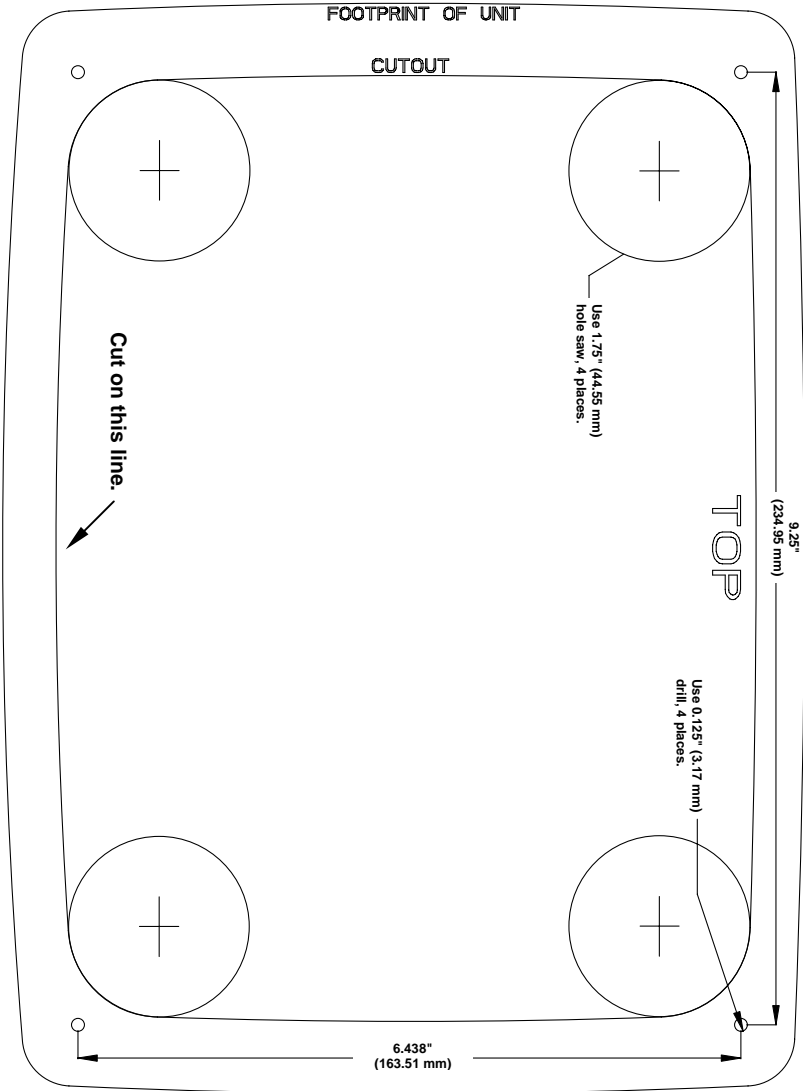

**FM-11 dash mounting template, part number 988-0154-691.**  
**NOTE: This drawing is not to scale and is for illustration only.**  
*Always verify template print dimensions before use.*

# How to Obtain Service...

## ...in the USA:

Contact the Factory Customer Service Department. Call toll-free:

**For Lowrance: 800-324-1356. For Eagle: 800-324-1354**

8 a.m. to 5 p.m. Central Standard Time, M-F

*Lowrance Electronics and Eagle Electronics may find it necessary to change or end their shipping policies, regulations and special offers at any time. They reserve the right to do so without notice.*

## ...in Canada:

Contact the Factory Customer Service Department. Call toll-free:

**800-661-3983**

**905-629-1614 (not toll-free)**

8 a.m. to 5 p.m. Eastern Standard Time, M-F

## ...outside Canada and the USA:

Contact the dealer in the country where you purchased your unit. To locate a dealer near you, see the instructions in paragraph number 1 below.

## Accessory Ordering Information

LEI Extras™, Inc. is the accessory source for sonar and GPS products manufactured by Lowrance Electronics and Eagle Electronics. To order Lowrance or Eagle accessories, please contact:

1) Your local marine dealer or consumer electronics store. To locate a Lowrance dealer, visit the web site, [www.lowrance.com](http://www.lowrance.com), and look for the Dealer Locator. To locate an Eagle dealer, visit the web site, [www.eaglesonar.com](http://www.eaglesonar.com), and look for the Dealer Locator. Or, consult your telephone directory for listings.

2) U.S. customers: LEI Extras Inc., PO Box 129, Catoosa, OK 74015-0129  
**Call toll free in the U.S., 800-324-0045**, 8 a.m. to 5 p.m. Central Standard Time, M-F, or visit our web site [www.lei-extras.com](http://www.lei-extras.com).

3) Canadian customers: Lowrance/Eagle Canada, 919 Matheson Blvd. E. Mississauga, Ontario L4W2R7 or fax 905-629-3118.

Call toll free in Canada, 800-661-3983, or dial 905 629-1614 (not toll free), 8 a.m. to 5 p.m. Eastern Standard Time, M-F.



Pub. 988-0154-921

Printed in USA 021507

© Copyright 2007  
All Rights Reserved  
LEI