

INSTALLATION AND OPERATION MANUAL
**MODELS LRG-1500A
AND LRG-1500M**
TRULINE RECORDER

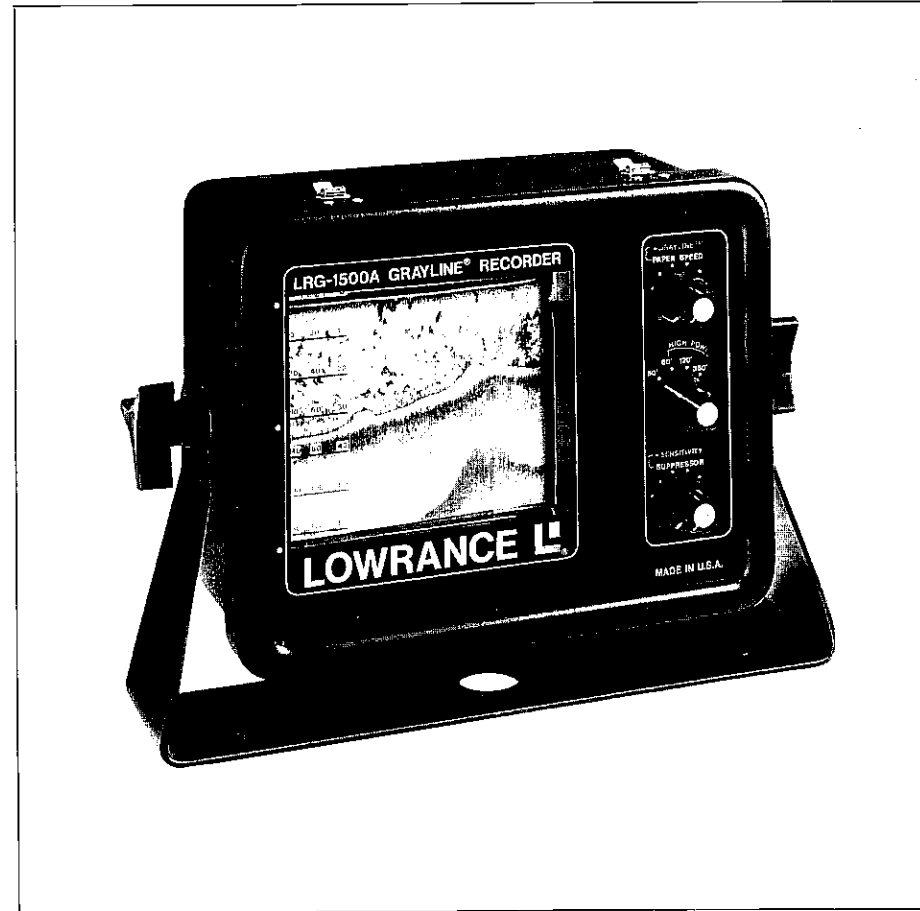

Printed in U.S.A.

988-0068-02

LOWRANCE ELECTRONICS, INC.
12000 E. SKELLY DR., TULSA, OKLA. 74128

NOTICE

Periodically wash the Transducer Face with soap and water to remove any oil film that may collect. Oil and dirt on the face will reduce sensitivity or may even prevent sounding.

GOT A PROBLEM? LET US HELP!

If you have a problem with your sonar unit, please give us a chance to help before sending it in for repair.

Assistance can often be extended by telephone or letter. Write or call one of our Authorized Service Centers or the Lowrance Electronics, Inc., Customer Service Department in Tulsa, OK. (*Toll-free 1-800-331-3889*).

Please detail the problem you are experiencing. Our Service Department may be able to save you the inconvenience of returning your unit.

If it is determined that your unit must be returned, full shipping instructions will be provided.

SCHEMATIC DIAGRAM AND PARTS LIST

Should you desire a Schematic Diagram and Parts list for your Lowrance TRUeline RECORDER, send \$1.00 to PARTS LIST, Lowrance Electronics, Inc., 12000 East Skelly Drive, Tulsa, Oklahoma 74128. Be sure and give us the Model Number and Serial Number of your SONAR INSTRUMENT.

WHAT IT IS

“Sonar” is an abbreviation meaning “sound navigation and ranging.” It was developed as a means of tracking enemy submarines during World War II. Sound — when transmitted through water — travels at approximately 4800 feet per second as compared to 1100 through air.

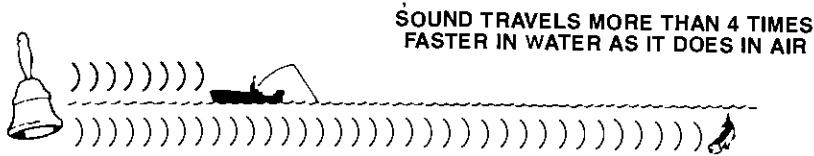

Fig. 1

4800 FEET PER SECOND IN WATER

In simple terms, an electrical impulse is converted into a sound wave and transmitted into the water. When the wave strikes an obstacle, it rebounds. Since the speed of sound in water is known — and constant — the time between the transmitted signal and the received echo can be measured and the distance to the obstacle determined. An electronic sonar unit can both send and receive the sound waves, as well as time, measure, and record them.

PRINCIPLE OF SONAR

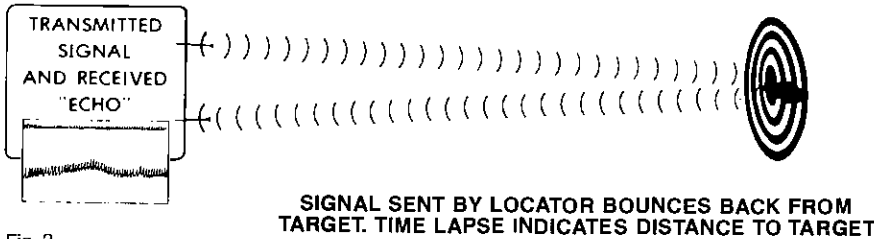

Fig. 2

The Lowrance Model LRG-1500A/M graph recorder is a compact unit specifically designed for sport fishermen. It has 900 watts typical peak-to-peak power, (112 watts RMS) features easy to read straight line recordings, has a “gray line” capability, and provides easy-to-read graphs with such clarity that even a single fish hovering just nine inches off the bottom is easily identified.

Full control of the system is at your finger tips to meet the changing demands of varying bottom conditions, water depth and boat speed. You can select the unit’s sensitivity setting, suppression level, depth range, paper speed, and the degree of “gray line” used to enhance the recorded information. The patented Lowrance variable suppression system not only filters out false signals without distorting the real ones, but is synchronized with the gray line function to provide clear signals under all conditions. The permanent record of what your sonar has “seen” is rolled and stored inside the case.

DO SECTION

- Do carry a spare fuse, *stylus belt*, and roll of paper.
- Do use the tape from a new roll or paper to attach it to the take-up spool.
- Do use the empty cardboard core from the last roll of paper on the take-up post.
- Do carry a pencil to make notes on the paper.
- Do keep the recorded graphs for future reference.
- Do clean the stylus belt and wheels with alcohol after every five rolls of paper.

DON'T SECTION

- DON'T OPEN THE CASE WHEN THE UNIT IS ON.
- Don't pull the platen assembly down when the stylus is at the front.
- Don't store any objects inside the case or behind the viewing door.
- Don't forget to tape the paper to the take-up core.
- Don't rotate the stylus belt up.
- Don't use oily cloths, strong solvents or abrasive cleansers.

TROUBLESHOOTING

SYMPTOM	WHAT TO DO
A. On/Off switch is “ON”, but the stylus and paper don't move	A. Check fuse; check connections at battery; tighten power cord connector
B. On/Off switch is “ON”, have zero mark, but no echoes or bottom signals	B. Be sure the transducer is plugged into the unit and the transducer is in contact with the water
C. The unit is ON, but paper does not move	C. Tape Paper to cardboard spool on take-up post
D. Recorder marks are faint or dim	D. Clean viewing door; replace the stylus
E. Recorded marks are very heavy; paper is torn by stylus	E. Bend the stylus slightly to reduce pressure on paper.

MAINTENANCE

NOTE: The stylus may be damaged if it is in front of the platen when the platen assembly is pulled down. *Always* move the stylus to the back side of the platen when changing the paper rolls. Remember to move the belt down to remove stylus.

Black carbon dust is created during the recording process. Use a soft, oil-free rag to clean the viewing door and metal platen behind the paper. Low pressure compressed air may be used to blow dust out of the case and away from moving parts *if* the air is dry and free of oil.

After every five rolls of paper, the stylus belt and the wheels it rides on should be wiped clean with a soft rag moistened with alcohol to remove carbon dust. Strong solvents or abrasive cleaners *should not* be used.

All mechanical connections should be checked periodically to be sure they haven't worked loose.

DO NOT apply any type of lubricant to the motors or gear trains.

DO NOT wash the unit with running water. Wiping it with a damp cloth to remove salt accumulations, dust, or road grime is all that's necessary.

HIGH VOLTAGE is present in the transmitter section when the unit is ON. No attempt should be made by any unauthorized person to modify or repair the electronic section.

Corrosion may occur at the power plug, in the fuse holder or power cord splices, or at the battery connections. All electrical connections should be checked periodically and cleaned as necessary with 400 grit sandpaper.

The face of the transducer, if mounted on the transom should be washed periodically with mild soapy water to remove any accumulated road grime or oily film. This is essential to have good contact between the transducer and the water.

Periodically, the rubber roller on the paper drive should be cleaned with a cloth dampened with alcohol, to improve the friction on the drive shaft. (See page 16, Figure 29).

HOW IT WORKS

When the unit is turned on, an electronically regulated motor drives a lightweight belt located at the right edge of the recording paper. The marking stylus is attached to this belt. When the stylus is at the top of the paper, the transmitter is triggered and a small mark is made at the top of the paper. This is called the zero mark, and represents the surface of the water.

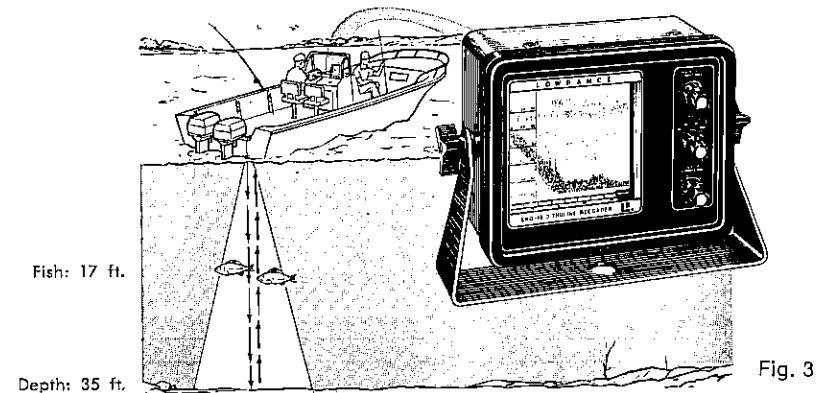

TRULINE RECORDER BOTH SEND AND RECEIVES SIGNALS. RECEIVED SIGNALS ARE INDICATED ON GRAPH PAPER.

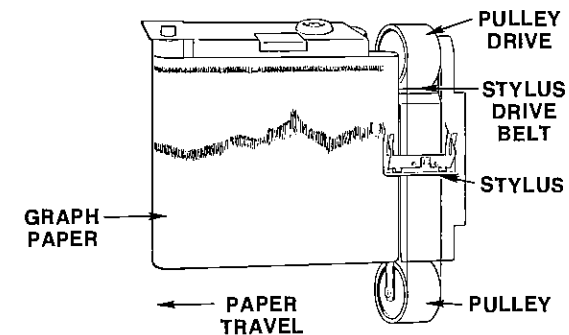

The stylus continues to move down the edge of the paper while the sound pulse is traveling through the water, and when an echo is detected, the stylus makes another mark on the paper. The depth of the object which reflected the echo can be read in feet by comparing its location on the paper to the depth scale on the left side of the viewing area.

A variable speed motor drives the paper graph. (The paper is treated so that the stylus will burn it to leave a *permanent*, black mark.) During one revolution of the stylus belt, a very narrow mark will be made by the flexible stylus, but the paper will move a small amount before the next revolution. Each mark will blend into the one before, so that a composite "picture" of the target will be made, one tiny mark at a time.

WHAT IT TELLS YOU

Small boat sonar systems are routinely used to measure water depth, examine bottom contours, and locate fish — but the capability of the LRG-1500A/M goes far beyond the ordinary. Clues to the composition of the bottom are given — schools of bait fish are easily distinguished from solitary game fish — there is a continuous display of information about bottom contours, submerged shipwrecks — fish as close together as six inches will be shown separately — concentrations of algae, moss or plankton can be identified — at trolling speeds individual fish are commonly recorded with a characteristic “arched” signature which distinguishes them from their surroundings — layers of water with different temperatures can be detected under good conditions, and vertical movement of fish, (up or down), can be shown.

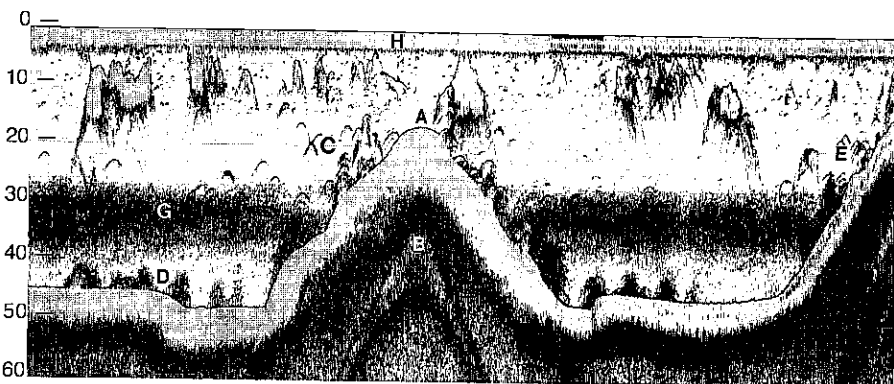

Fig. 5

LOWRANCE STRAIGHT LINE RECORDER

This is a sample of the graph printout by a Lowrance Straight Line Recorder. A and D indicate bottom depths of 16 feet and 46 feet respectively. B represents an echo (a second signal) caused from a very hard or reflective bottom surface which causes the sonar signal to bounce back to the water's surface, return to the bottom and reflect back to the receiver. Therefore, the time for a sonar signal to travel to the bottom and back to the surface has doubled. If the true bottom reading is 16 feet, the echo will appear at 32 feet. If the true depth were ten feet, then the echo would occur 20 feet. C and E indicate large fish. The thermocline is indicated at 28 feet (G) with schools of baitfish scattered from 4 feet to 20 feet. It is also possible to see small and medium size fish by their “arched” signatures. The dark line across the top of the paper graph (H) indicates “zero” or the water's surface.



Fig. 38

4. Grasp the belt at the stylus holder with the thumb and forefinger and move it gently to the left while pushing the belt off the wheels with the other forefinger. (See Figure 38.)
5. Position the new belt on the wheels by reversing the procedure used to remove the old one. BE SURE the fingers of the new stylus are pointed UP.
6. Close the front of the case. Latch both catches on the top of the unit.

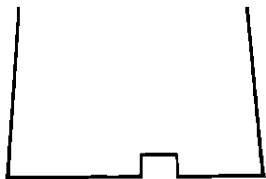

Fig. 35

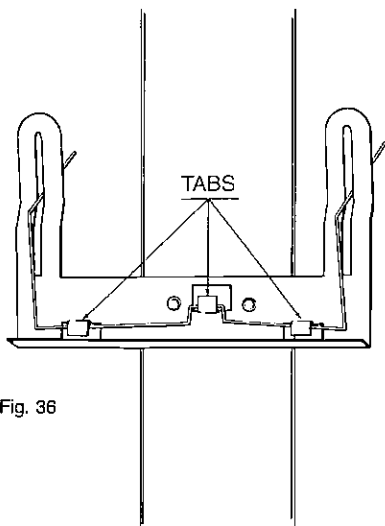
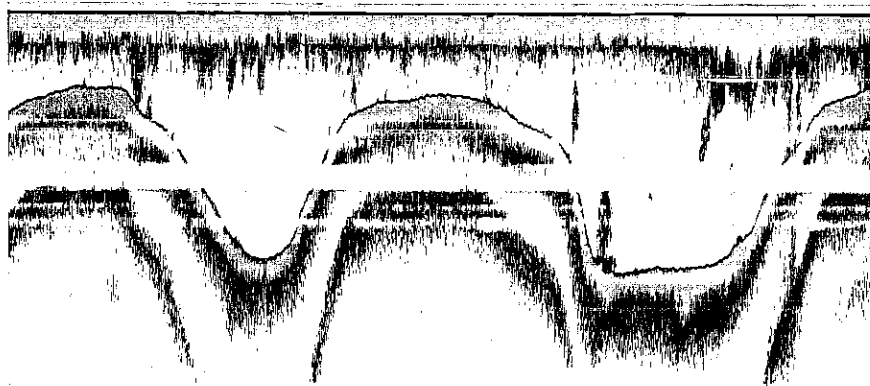

Fig. 36

Figure 37



7. After installing, if the stylus won't print all the way down the paper, (See Figure 37) bend the right leg down so that more pressure is exerted against the stainless steel plate. If it still does not print all the way, bend the left leg down more (but not so far that it digs into the paper).
8. Close the front of the case. Latch both catches on the top of the case.

STYLUS BELT REPLACEMENT

— CAUTION —

High voltage is present in the electronic section when the unit is turned on.

1. **TURN THE UNIT OFF.**
2. Release both catches on the top of the case. Pull out and down on the top of the case front to expose the stylus belt.
3. The stylus belt rides over two wheels located at the right edge of the platen assembly. Refer to Figure 4 on page 3. Move the front of the belt **DOWN** to position the stylus at the center of the platen.

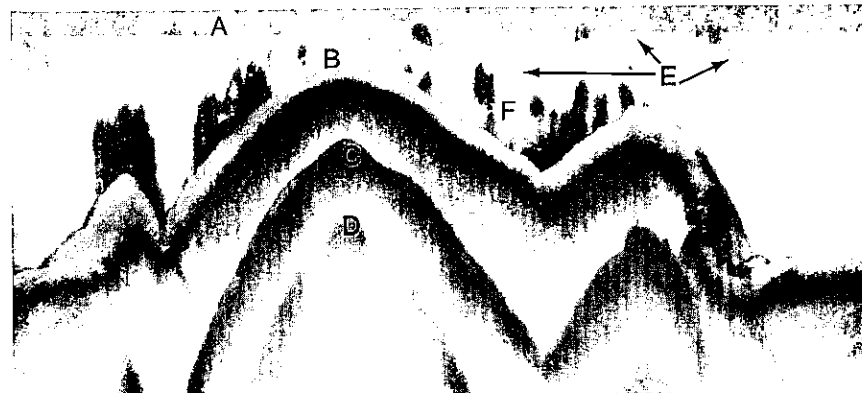
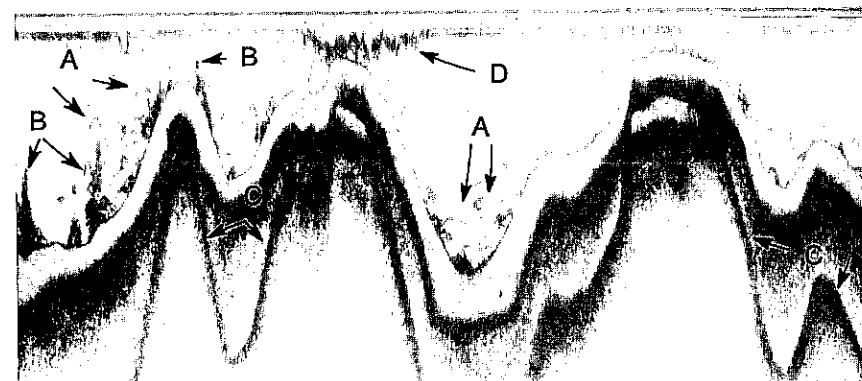

Fig. 6

A. ALGAE AND PLANKTON
B. TRUE BOTTOM SIGNAL
C. SECOND ECHO

D. THIRD ECHO
E. FISH SIGNALS
F. TREES

The LRG-1500A/M is a complete sonar. Its controls are simple enough for the occasional fisherman, and flexible enough to satisfy the most demanding pro. We encourage you to study the remainder of this booklet to get the most from your investment and to boost your boating and fishing pleasure.



60' SCALE

Fig. 7

BE SURE to insert the two rubber grommets on gimbal bracket. The larger side (larger diameter) of grommet goes on inside of gimbal bracket so that it is sandwiched between gimbal bracket and sonar instrument (see drawings). The grommets provide friction to hold the unit at the desired angle.

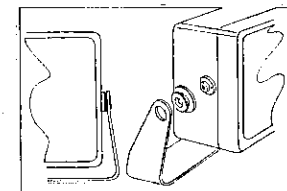

INSTALLATION

MOUNTING

Any convenient area is suitable for mounting, providing the unit can be tilted for the best viewing angle. There are eight mounting holes in the base of the gimbal bracket for wood screws or thru-bolts. If necessary, a wooden stiffener can be used on the back side of thin fiberglass panels.

If the desired mounting location is closer than 18" to a magnetic compass, a trial run should be made, *with the unit in operation*, to be sure the compass readings are not affected.

POWER CONNECTIONS

12 volt DC power for the depth sounder is supplied from the boat's 12 volt electrical system. Power may be picked up at an accessory or power buss, but if you have problems with electrical interference (indicated by extraneous flashes on the dial) it can be minimized by connecting power directly to the battery.

If a longer power cable is required, use ordinary #18 lamp cord available at any hardware store. Splices should be soldered. If this can't be done, use crimp-type connectors. Simple twisting of splices may result in intermittent power connections which can cause interference. Tape all splices with plastic electrical tape.

IMPORTANT NOTICE

When installing the power cable, make certain that the in-line fuse supplied with the unit is attached to the center conductor of the power cable as close to the power source as possible. This will protect both the unit and the power cable in case either is ever shorted. A connector is supplied to attach the fuse to the power cable.

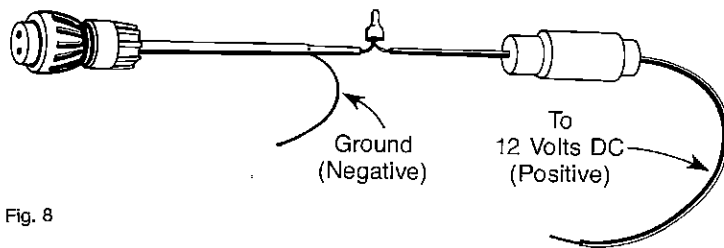

Fig. 8

The positive conductor in the power cable is the center conductor. The unit is protected from accidental polarity reversals and no damage will result if battery connections are wrong. (However, the unit will not work.)

STYLUS REPLACEMENT

— CAUTION —

High voltage is present in the electronic section when the unit is turned on.

1. TURN THE UNIT OFF.
2. Release both catches on the top of the case. Pull out and down on the top of the case front to expose the stylus belt. (See Figure 34.)
3. The stylus belt rides over two wheels located at the right edge of the platen assembly. Move the front of the belt DOWN to position the stylus at the center of the platen.

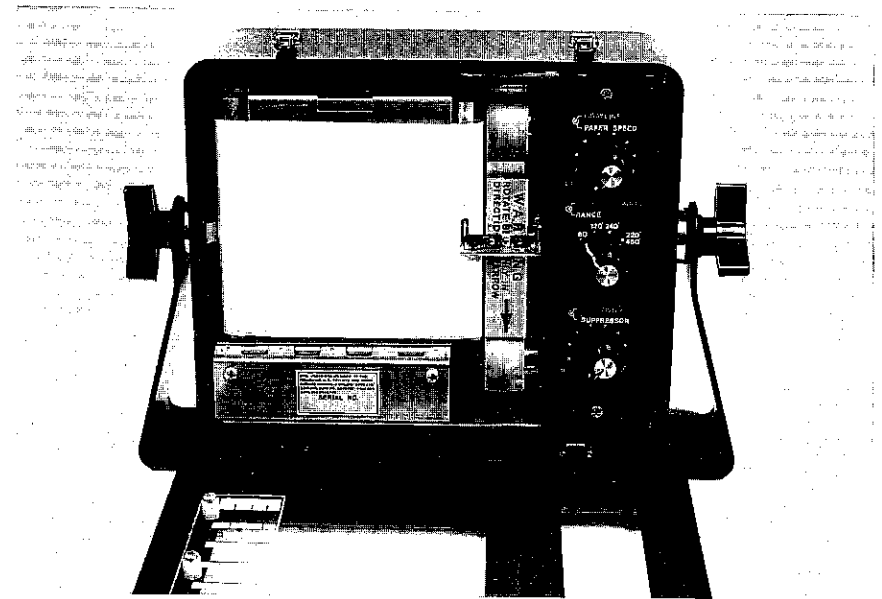

Fig. 26

4. Hold the stylus belt stationary with one finger, and remove the old stylus by starting at its left edge and moving it out from under the tabs on the stylus holder.
5. Before installing the new stylus, be sure it is bent properly by comparing it to Figure 35.
6. Refer to Figure 36 to be sure the new stylus is positioned correctly under the tabs on the holder. Be sure it moves freely in the two slots. If not, bend the stylus away from the edge it is rubbing on until it does move freely.

10. Push the platen assembly back to its operating position. Be sure it engages the catch inside the top of the case. (See Figure 32.)

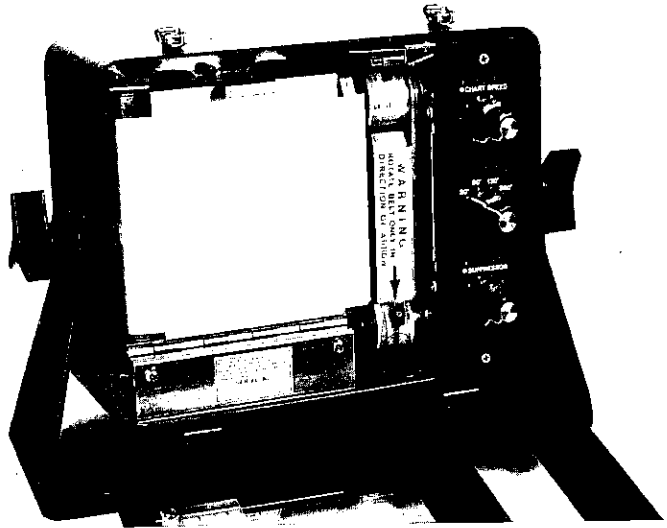

Fig. 32

11. Close the front of the case. Latch both catches on the top of the case. (See Figure 33.)

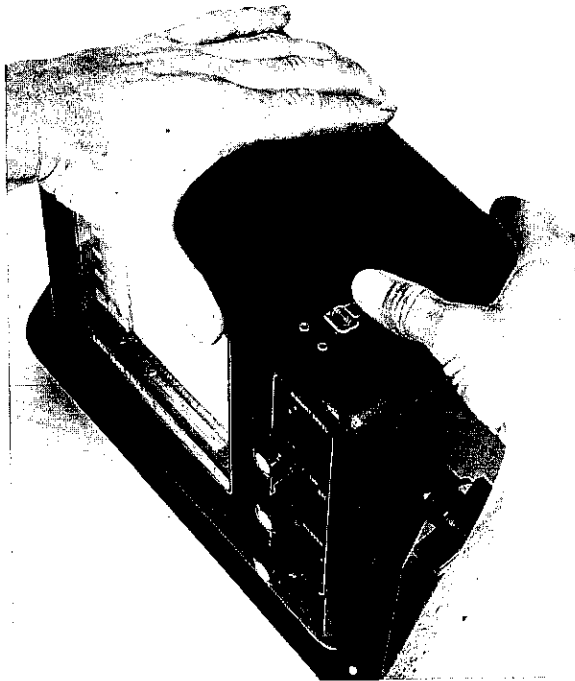

Fig. 33

12. Turn the unit on. Move the Chart Speed knob fully clockwise. Watch the paper long enough to be sure it is moving smoothly and evenly across the platen. If the paper flutters or begins to run "up-hill", repeat Step 8.

OPERATION

SCALE KNOB — used to select recording depth. There are four positions:

LRG-1500A

- 60 feet, with low transmitter power
- 60 feet, with high transmitter power
- 120 feet, with high transmitter power
- 360 feet, with high transmitter power

METRIC LRG-1500M

- 18 meters, with low transmitter power
- 18 meters, with high transmitter power
- 30 meters, with high transmitter power
- 60 meters, with high transmitter power

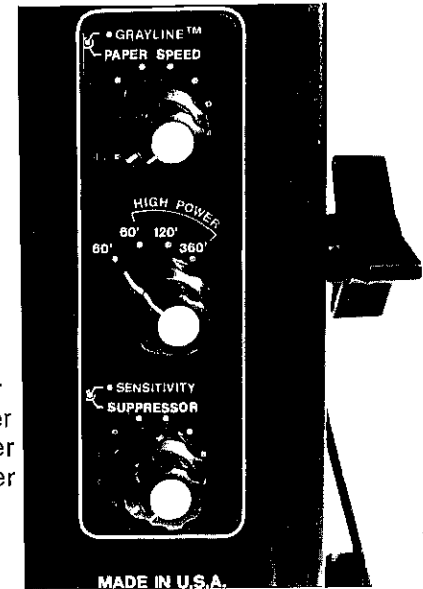

Fig. 9

ON/OFF AND SENSITIVITY KNOB — Rotate the On/Off knob clockwise to turn the unit on. The Sensitivity knob works much like the volume control on a radio, that is, weaker signals will be detected with higher settings of the knob. When cruising, or at other times when just simple bottom-contour information is desired, the Sensitivity setting can be low. In deep water or over soft, muddy bottoms, (which produce weak echoes), the setting will have to be higher.

When high Sensitivity settings are used, a second bottom echo will appear. This is normal and is caused by the returning signal reflecting off the surface of the water, making a second trip to the bottom and back.

When detailed information about brush piles, individual fish, or the thermocline is desired, the Sensitivity knob should be set at about 3/4 point. Refer to the illustration below to see what effect the Sensitivity setting has on the recorded information.

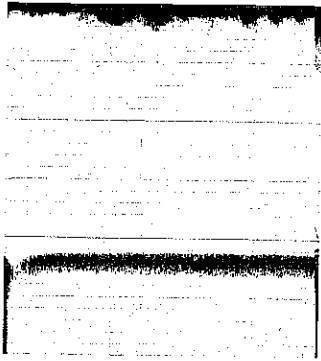

Fig. 10

SENSITIVITY: 1/4 SETTING
ONLY THE BOTTOM SIGNAL
IS DISPLAYED. ALL FISH
SIGNALS ARE LOST.



Fig. 11

SENSITIVITY: 3/4 SETTING
A. TREE
B. THERMOCLINE
C. BAITFISH SCHOOL
D. GAME FISH (NOTE: ELONGATED
ARCHED SIGNATURES DUE TO
VERY SLOW BOAT SPEED)

Recording individual fish with an "arched" signature can usually be accomplished at trolling speed with the Sensitivity knob at the 3/4 point, or higher. Refer to the section "Arched Signatures," on page 10 for more information about this important function of your recorder.

SUPPRESSION KNOB — Is used to reduce interference from noise. Noise, in electronic terms, is any undesired signal. It can be caused by an electrical source, (such as the engine's ignition system), or by air bubbles in disturbed water which is called cavitation noise. In both cases, the noise could produce unwanted marks on the paper. (See page 11, Figure 18.) Fortunately, noise pulses are relatively short in time compared to real sonar signals. Advancing the Suppression knob will cause the system to reject these unwanted, short pulses without reducing the sensitivity in any way.

This patented design is exclusive with Lowrance. However, with high suppression settings, the graph record becomes coarse and the ability to separate fish from the bottom or from other fish will be decreased. (See page 12, Figure 22.) Therefore, the *lower* the suppression setting the better. Advance the knob setting only as far as necessary to remove the erratic, unwanted noise marks. Most of the time at low or trolling speeds, no suppression will be needed.

PAPER SPEED KNOB — Controls the speed of the chart paper. For good detail when trolling and looking for fish, or when running at high speed, turn the paper speed knob up at least half-way. For best detail, turn it up to maximum. This will show proper fish arches at low speeds and keeps high speed information from being compressed. (See "How to Read Graphs.")

8. Draw the end of the paper across the face of the platen, around the friction roller, over the take-up core, and tape it squarely to the take-up core. (See Figure 30.) (Hint: small strips of tape may be stored inside housing.)

Fig. 30

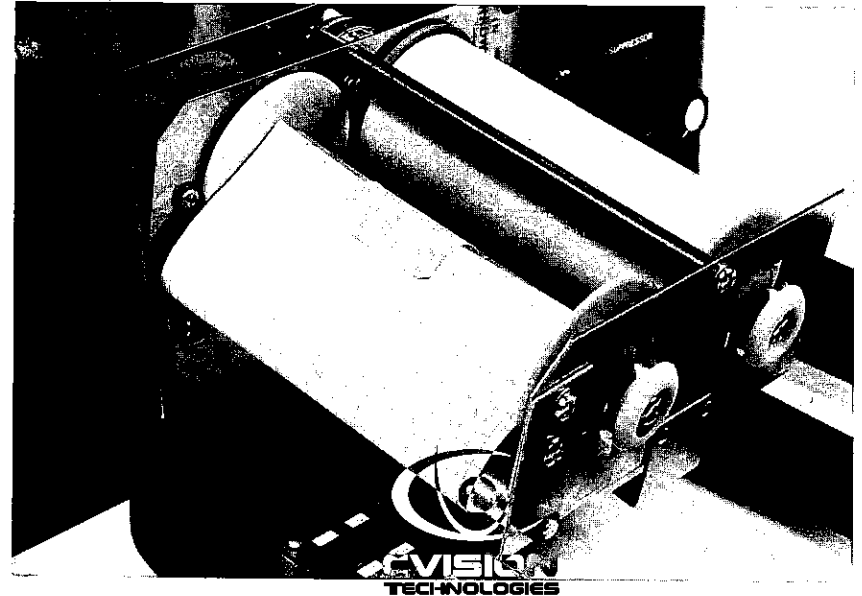

9. Hold the take-up spool, and turn the supply spool clockwise to put a small amount of tension on the paper. It should be snug against the platen. (See Figure 31.)

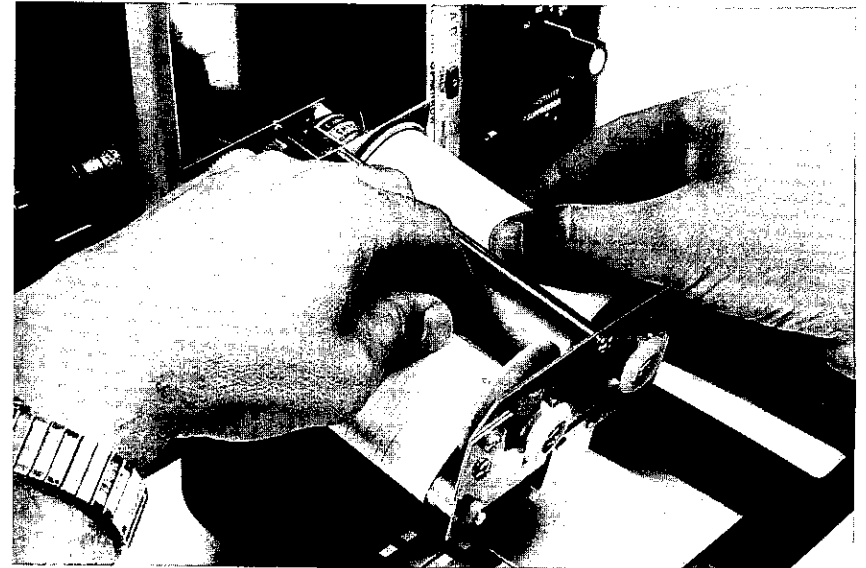

Fig. 31

6. Remove the empty supply core from the right side in the same manner. Align the two notches in the core with the tabs on the lower take-up spool. (See Fig. 28) Push the paper retainer knob in and rotate it until it locks into place.

NOTE: Both LPG-602 and LPG-603 chart paper can be used in this unit. However, to use the paper core from the LPG-602 chart paper on the *take-up* side of the chart drive, notches must be cut into the core. These notches should be 1/4" wide by 3/16" deep on both sides of the core. LPG-603 chart paper comes with the notches so no modification is necessary when using the paper core on the take-up side of the paper drive. Both LPG-602 and LPG-603 chart paper can be used on the *supply* side of the chart drive without modification.

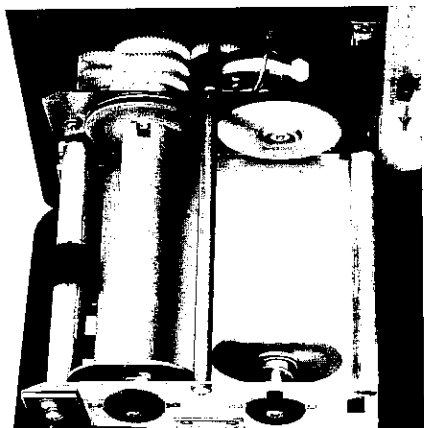

Fig. 28

7. Put a fresh roll of paper in position on the centering posts of the paper spool end caps on the supply side (right) of the platen assembly. *The paper must spool off the bottom of the roll.* (See Figure 29.)

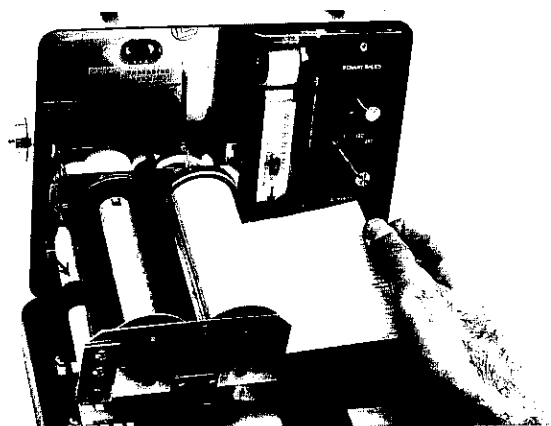
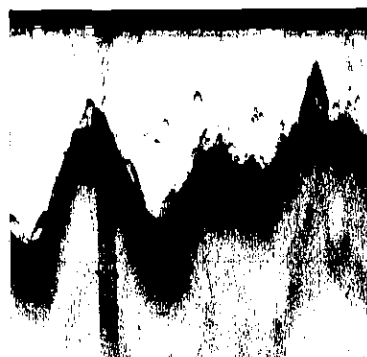
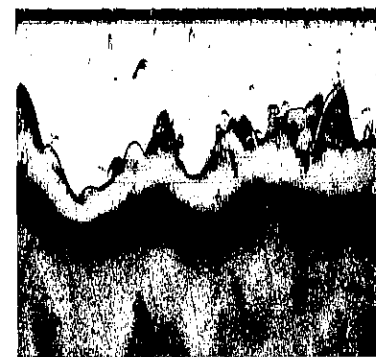

Fig. 29 Arrow indicates friction roller

When charting on the 360" scale in deep water, the paper speed should be turned down to no more than half-way for the best record. If gaps appear between stylus strikes, the paper is running too fast. The paper speed may also be turned down to conserve paper when not looking for fish or concerned with fine detail.



BOULDERS/LARGE ROCKS Fig. 12
GRAY-LINE: "OFF"



BOULDERS/LARGE ROCKS Fig. 13
GRAY-LINE: "ON"



GRAY-LINE: "OFF" Fig. 14
A. FISH
B. TREES
C. FISH IN TREES
D. BAIT FISH SCHOOL

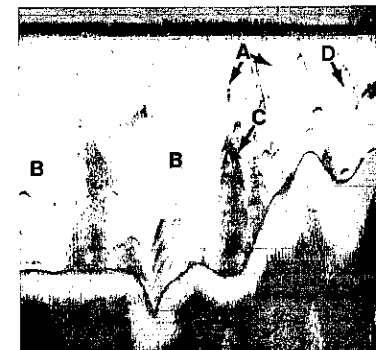

GRAY-LINE: "ON" Fig. 15
A. FISH
B. TREES
C. FISH IN TREES
D. BAIT FISH SCHOOL

GRAY LINE ON/OFF KNOB — The Gray Line function can be used to outline the bottom contour which might otherwise be hidden beneath trees and brush; it can also give clues to the composition of the bottom. A hard bottom returns a very strong signal causing a wide gray line. A soft, muddy or weedy bottom returns a weaker signal which is emphasized with a narrow gray line. Do not advance the control too far or it will gray line on fish, trees, etc. In water less than 30', just click the knob "on" — do not advance the control knob.

HOW TO READ GRAPHS

“ARCHED SIGNATURES” — A remarkable advantage of the LRG-1500 A/M is that it can record individual fish with a characteristic arched mark that separates them from their stationary surroundings. The reason for this is shown below. The distance to a fish when it moves into the sonar’s cone of sound is shown as “A” in the drawing. When the fish has moved to the center of the cone, the distance to it will be shorter, (line “B”), and as it moves out of the cone, the distance will increase again as shown in line “C”.

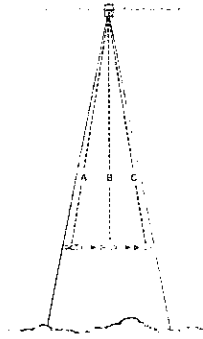
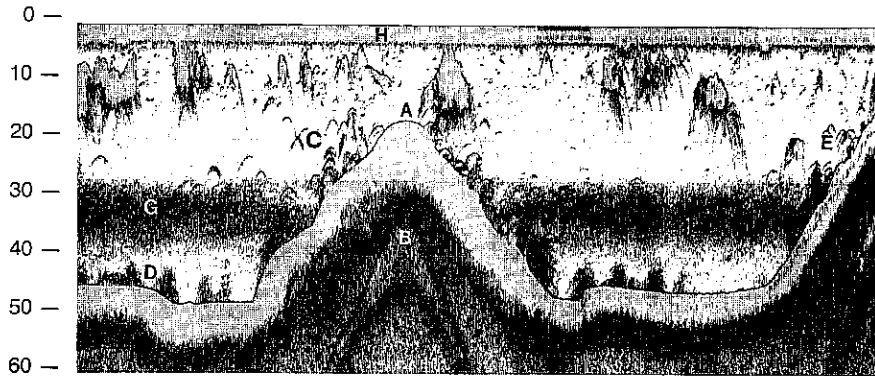

Fig. 16

If a partial arch occurs most of the time on your unit (the mark curves up but does not curve back down), it is because the transducer is not aimed straight down.

Sharp, well-defined signatures will occur most often when the Sensitivity knob is set at the 3/4 point or higher. (See (C), Figure 17.) Remember, too, that there must be some movement between the fish and boat to develop the arched mark.

Fig. 17



THERMOCLINES — The temperature of water in the lake is seldom constant from top to bottom. Layers of different temperatures form, and the junction of a warm and cool layer of water is called a thermocline. The depth and thickness of the thermocline can vary with the season or time of day. In deep lakes there may be two or more, at different depths. Thermoclines are important to the fisherman because they are areas which fish are active. Many times bait fish will be above the thermocline while larger game fish suspend just below it. (See (G), Figure 17.)

Your Lowrance Model LRG-1500A/M can detect this invisible layer in the water, but the Sensitivity knob will probably have to be set at the 3/4 point, or higher.

5. To remove the full take-up roll, push in and rotate the left paper retainer knob until it snaps out. (See Figure 26.) The roll can now be easily removed from the paper spool end caps. (See Figure 27.)

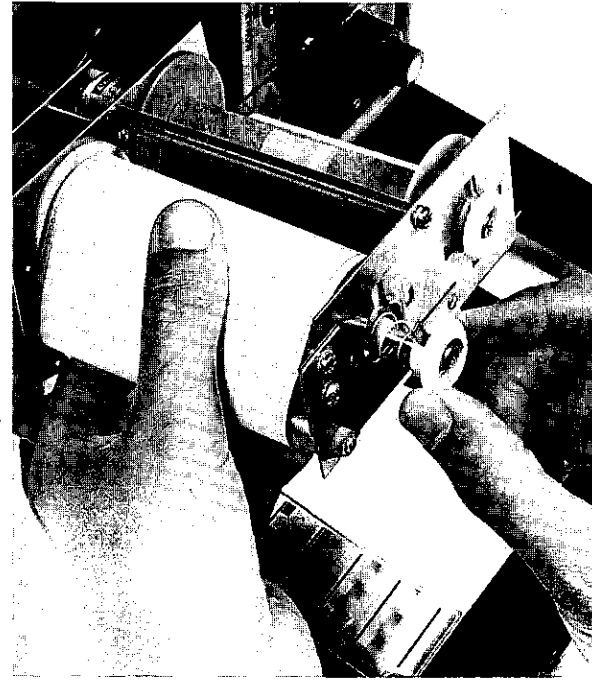

Fig. 26

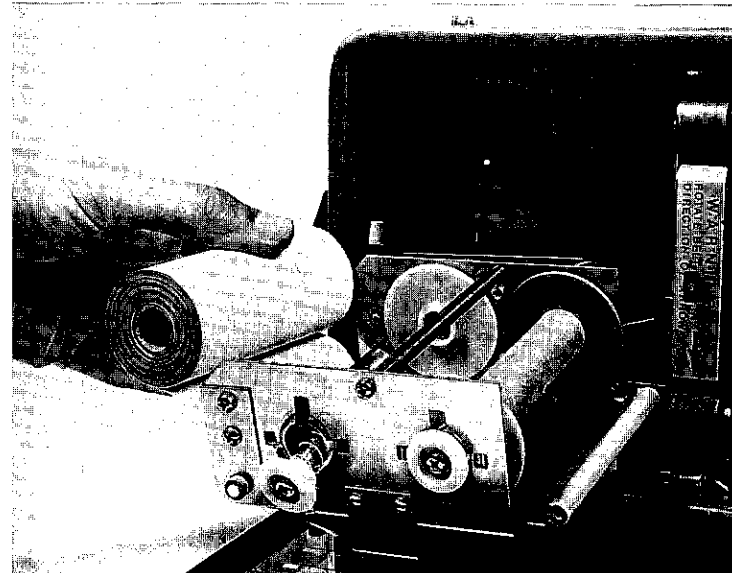

Fig. 27

3. Move the stylus belt DOWN, (on the right side of the viewing area), to position the marking stylus on the *back* side of the platen. NEVER move the belt up — the stylus may be damaged.

SPECIAL NOTE: The stylus may be damaged if the platen assembly is pulled down *unless* the stylus has been moved to the back side of the platen.

4. Pull out and down on the tab at the top, center of the platen assembly to expose the paper spools. (See Figure 25.)

Fig. 25

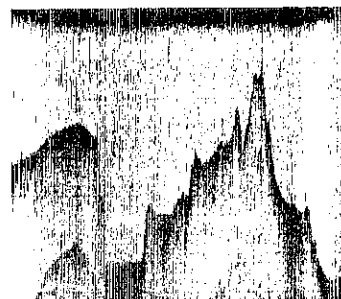
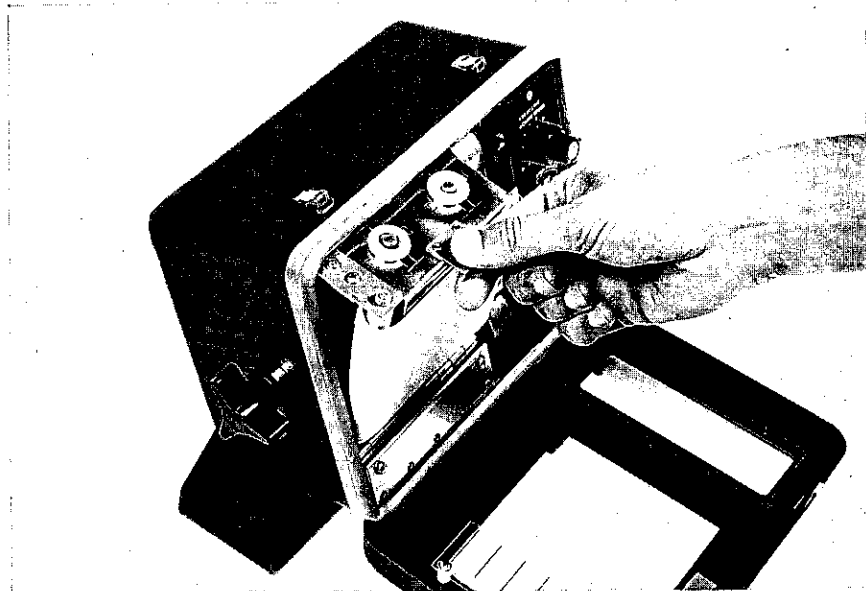

High Speed (46 M.P.H.)
 SUPPRESSION: OFF
 SENSITIVITY: ON — 1/2 POSITION
 NOTE POOR RECORD CAUSED
 BY NOT USING SUPPRESSION
 WHEN AT HIGH SPEED.

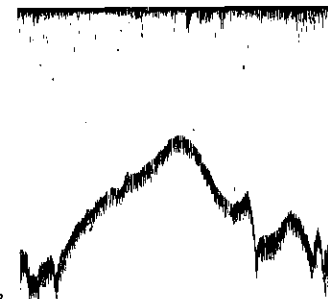

Fig. 18

High Speed (46 M.P.H.)
 SUPPRESSION: ON — ADEQUATE SETTING
 SENSITIVITY: ON — 1/2 POSITION

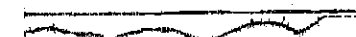
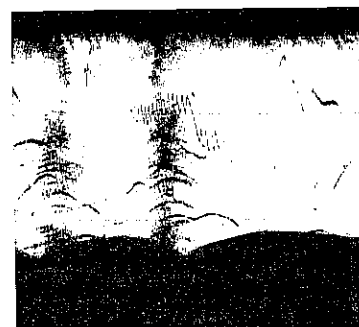
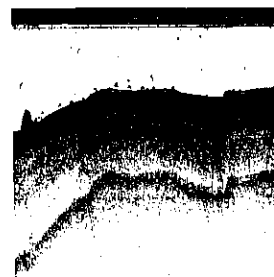

Fig. 19

- A. JIGGING A 1 1/4 oz. HOPKINS SPOON IN SUBMERGED TREE.
- B. FISH SIGNALS (BOAT DRIFTING VERY SLOWLY OVER FISH)
- C. BAIT FISH

SCALE: 0 TO 60 FEET
 PAPER SPEED: SLOW
 SUPPRESSION: OFF
 DEPTHS: RECORDED FROM 18
 INCHES TO 7 1/2 FEET



GRAY-LINE: "OFF"
 A. FISH ON OR NEAR BOTTOM

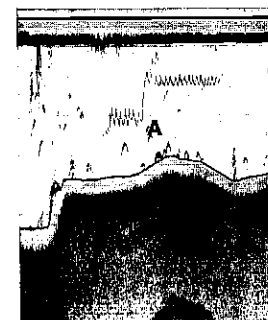

Fig. 20

GRAY-LINE: "ON"
 A. FISH ON OR NEAR BOTTOM

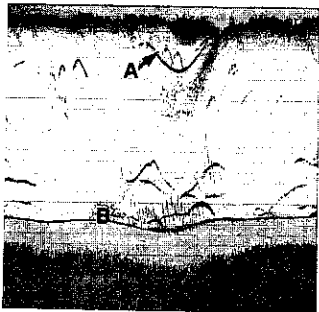

Fig. 21



- A. A FISH SUSPENDED UNDER BOAT
- B. FISH SWIMMING UP TOWARDS BOAT
- C. SCHOOL OF BAIT FISH
- D. SURFACE CLUTTER

SCALE: 0 TO 60 FEET
GRAY-LINE: "OFF"

- A. FISH DRIFTING UNDER BOAT. FISH MOVED FROM 13½ FEET TO 21 FEET TO 12 FEET WHILE DRIFTING/SWIMMING WITHIN THE CONE OF SOUND.
 - B. JIGGING A LEAD-HEAD LURE OFF BOTTOM.
- SCALE: 0 TO 60 FEET
GRAY-LINE: "ON"



Fig. 22

SUPPRESSION: TOO HIGH
(NOTE THAT RECORDER SIGNALS FROM SCHOOLS OF BAIT FISH ARE ELONGATED AND RUN TOGETHER WITH THE BOTTOM.)

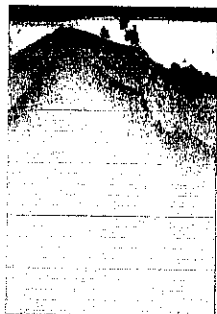

SUPPRESSION: PROPER SETTING
(NOTE DISTINCT INDIVIDUAL SCHOOLS OF BAIT FISH.)

END-OF-PAPER MARKER — The graph paper used in the LRG-1500A/M has a red line printed at the bottom of the paper to signify when there is only 2 to 3 feet before the end of the paper (See Figure 23 on Page 13.)

PAPER LOADING

— CAUTION —

High voltage is present in the electronic section when the unit is turned on.

1. TURN THE UNIT OFF.
2. Release both catches on the top of the case. Pull out and down on the top of the case front to expose the platen assembly. (See Figure 24.)

Fig. 23

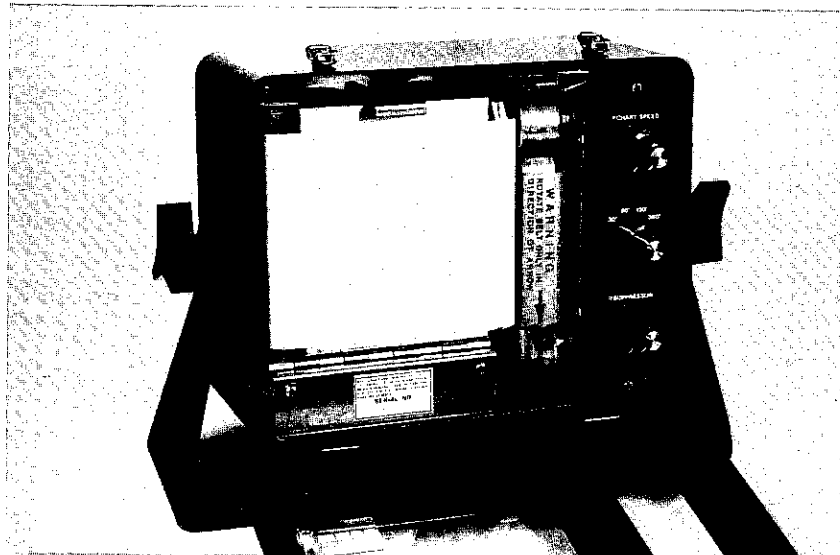
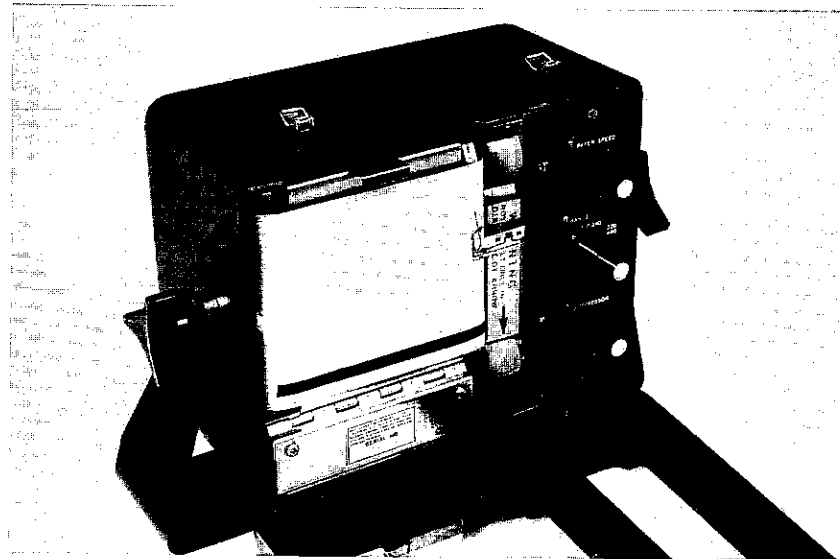

Fig. 24